

The InSinkErator Food Waste Disposer should be a part of every kitchen. The InSinkErator invented garbage disposers in 1927, and continues to be the world's largest manufacturer of disposers ever since. A benchmark for style and convenience, if you need an answer to the messy issue of food waste disposal, InSinkErator is the brand to trust.

WHY USE A FOOD WASTE DISPOSER?

Enhance your kitchen, enhance your life. High quality appliances make a real difference to how you equip and use the most important room in the house – your kitchen. Food Waste Disposers offers invaluable benefits for your family, and the community at large.

- NO INSECTS, PESTS, RODENTS**
Insects, pests and rodents breed in the presence of leftover food waste. Using a food waste disposer eliminates this possibility.
- NO ODOUR**
Timely disposal of peels or leftover food means less smelly kitchens.
- CLEANER KITCHEN**
Immediately dispose food waste while cooking and after eating. No leftovers, no mess, no waste of time cleaning and winding up.
- CLEANER COMMUNITY**
Food waste disposers ensure that wet & dry waste is segregated. They prevent roadside littering; reduce expense of collection, transportation of food waste, and reduces use of plastic garbage bags.



ADVANCED TECHNOLOGY



QUICKLOCK™ SINK MOUNT
"twist-on, twist-off" sink mount makes installation fast and easy

SOUNDSEAL™ TECHNOLOGY
Anti-Vibration Mount™ Quiet Collar™ & Sound Limiter™ insulation technology.

MULTIGRIND™ TECHNOLOGY
3-stage design makes quick work of both hard and fibrous foods.

DURADRIVE™ INDUCTION MOTOR
Powerful, heavy-duty motors ensure high performance and long life.

POWERBOOST™ MICRO PROCESSOR
Delivers more power to boost the grinding capability.



Cut-away of Model Evolution 200.

SAFE ON THE SEPTIC

InSinkErator Food Waste Disposer have always been safe for properly sized septic systems. For example, if your system is sized for a dishwasher or clothes washer, it can handle a disposer. After all, a disposer uses only about as much water per day as one flush of a toilet.

ENVIRONMENTAL BENEFITS

Each year in India tonnes of food waste is trucked to landfills. Once there, it quickly decomposes and produces methane, an environmentally harmful greenhouse gas at least 21 times more potent than CO2. Our food waste disposers provide a convenient and environmentally friendly alternative to transporting leftovers to landfills. Plus, capable wastewater treatment plants can even recycle food scraps into energy and fertilizer.

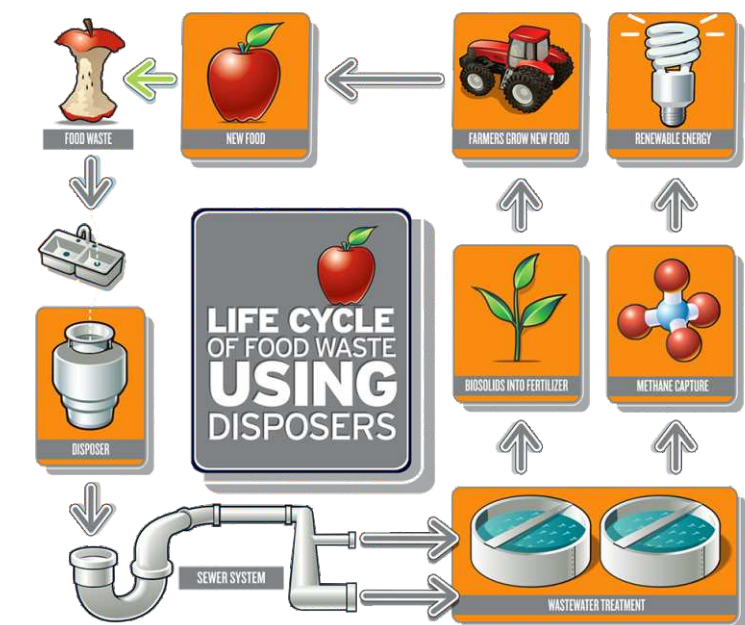

Description of wastewater treatment plant with anaerobic digestion, co-generation and beneficial reuse of bio-solids.

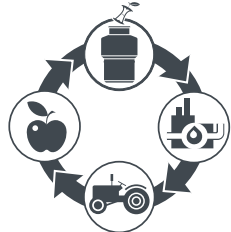

FEED A DISPOSER. STARVE A LANDFILL.

HOW TO SELECT MY FOOD WASTE DISPOSER?

	Evolution 200	Evolution 100	Model 66	Model 56	Model 46
Sound Reduction Technology	Ultra-Quiet	Quieter	Quiet	Quiet	Standard
Number of Grind Stages	GRINDS 3x	GRINDS 2x	GRINDS 1x	GRINDS 1x	GRINDS 1x
Motor	1 HP (120V) .75 HP (240V)	.75 HP	.75 HP	.55 HP	.55 HP
Warranty	6 Years	5 Years	4 Years	3 Years	2 Years
Built-In Air Switch	●	●	●	●	
Power Booster Circuit	●				
Auto Reverse	●	●			
Sink Stopper	Stainless Steel Strainer Basket	Stainless Steel Strainer Basket	1-Piece Stainless Steel	Plastic	Plastic
Easy Clean Baffle	Antimicrobial, Removeable	Antimicrobial, Removeable	Removeable	Removeable	Permanent
Grind Chamber Capacity	1180ml	1005ml	980ml	980ml	980ml
Stainless Steel Grind Elements	●	●	●	●	
Cover Control Compatible	●	●			



INPL01/010720



The World's Best Selling Food Waste Disposers!





MODEL 46 FOOD WASTE DISPOSER

The entry level InSinkErator model, suitable for lighter use in smaller households.

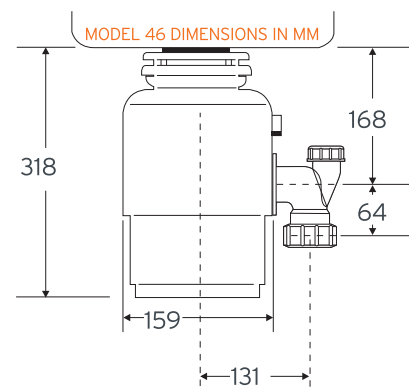

InSinkErator reserves the right to change product specifications without prior notice. The disposers described are for household use. Usage in commercial situations is not covered by warranty.

- BASIC SOUND REDUCTION TECHNOLOGY
- AIR SWITCH KIT* AVAILABLE (33MM HOLE FOR BUTTON)
- 1 STAGE GRINDING SYSTEM
- 0.55HP DURA-DRIVE™ HEAVY DUTY INDUCTION MOTOR
- GRIND CHAMBER 980ML CAPACITY
- 2 YEAR WARRANTY
- QUICKLOCK™ SINK MOUNT FOR EASY INSTALLATION
- MADE IN THE USA

*optional



MODEL 56 FOOD WASTE DISPOSER

This mid-range model is perfect for regular use in smaller households.

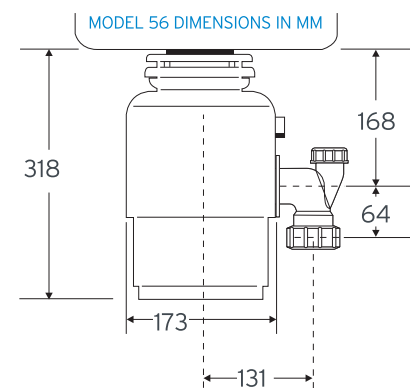

InSinkErator reserves the right to change product specifications without prior notice. The disposers described are for household use. Usage in commercial situations is not covered by warranty.

- BASIC SOUND REDUCTION TECHNOLOGY
- 0.55HP DURA-DRIVE™ HEAVY DUTY INDUCTION MOTOR
- 1 STAGE STAINLESS GRINDING SYSTEM
- QUICKLOCK™ SINK MOUNT FOR EASY INSTALLATION
- STAINLESS STEEL GRIND CHAMBER 980ML CAPACITY
- 3 YEAR WARRANTY
- BUILT-IN AIR SWITCH (33MM HOLE FOR BUTTON)
- MADE IN THE USA



MODEL 66 FOOD WASTE DISPOSER

This top model in our standard range, offering high performance, continuous feed operation and able to handle a wide variety of food waste.

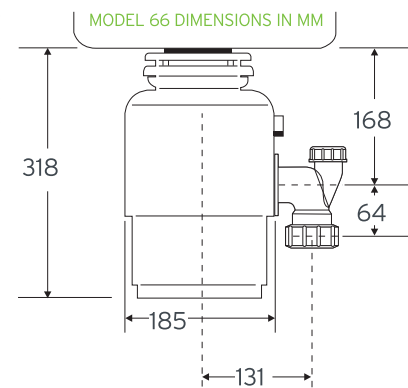

InSinkErator reserves the right to change product specifications without prior notice. The disposers described are for household use. Usage in commercial situations is not covered by warranty.

- BASIC SOUND REDUCTION TECHNOLOGY
- 0.75HP DURA-DRIVE™ HEAVY DUTY INDUCTION MOTOR
- 1 STAGE STAINLESS GRINDING SYSTEM
- QUICKLOCK™ SINK MOUNT FOR EASY INSTALLATION
- STAINLESS STEEL GRIND CHAMBER 980ML CAPACITY
- 4 YEAR WARRANTY
- BUILT-IN AIR SWITCH (33MM HOLE FOR BUTTON)
- MADE IN THE USA



EVOLUTION™ 100 TECHNOLOGY

Featuring two-stage grinding combined with SoundSeal™ Plus technology, the Evolution 100 is more powerful and quieter than our standard range. It virtually grinds any food waste, including difficult items such as bones and potato peel.

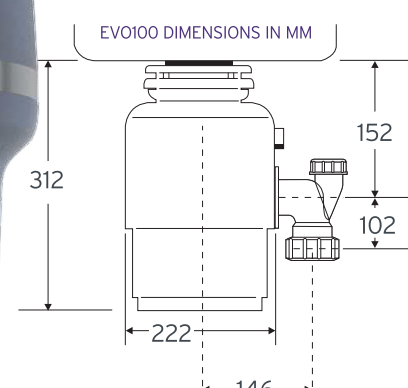

InSinkErator reserves the right to change product specifications without prior notice. The disposers described are for household use. Usage in commercial situations is not covered by warranty.

- SOUNDSEAL PLUS™ EVOLUTION QUIETER TECHNOLOGY
- 0.75HP DURA-DRIVE™ HEAVY DUTY INDUCTION MOTOR
- MULTIGRIND PLUS™ 2 STAGE STAINLESS GRINDING SYSTEM WITH AUTO REVERSE ACTION
- QUICKLOCK™ SINK MOUNT FOR EASY INSTALLATION
- STAINLESS STEEL GRINDING CHAMBER 1005ML LARGE CAPACITY
- 5 YEAR WARRANTY
- BUILT-IN AIR SWITCH (33MM HOLE FOR BUTTON)
- MADE IN THE USA



EVOLUTION™ 200 TECHNOLOGY

The Evolution 200 with it's three stage grind technology & SoundSeal™ Plus, makes it our most powerful & quietest model. Don't worry about what you can and can't grind... the Evolution 200 grinds all food waste.

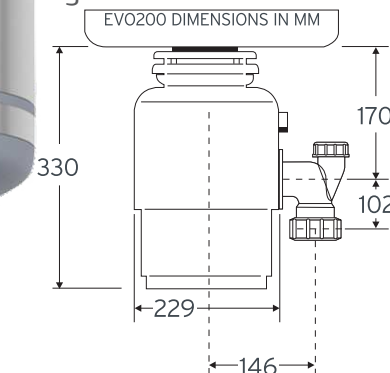

InSinkErator reserves the right to change product specifications without prior notice. The disposers described are for household use. Usage in commercial situations is not covered by warranty.

- SOUNDSEAL PLUS™ EVOLUTION ULTRA-QUIET TECHNOLOGY
- 0.75HP DURA-DRIVE™ HEAVY DUTY INDUCTION MOTOR
- MULTIGRIND PLUS™ 3 STAGE STAINLESS GRINDING SYSTEM WITH AUTO REVERSE ACTION
- QUICKLOCK™ SINK MOUNT FOR EASY INSTALLATION
- STAINLESS STEEL GRINDING CHAMBER 1180ML LARGE CAPACITY
- 6 YEAR WARRANTY
- BUILT-IN AIR SWITCH (33MM HOLE FOR BUTTON)
- MADE IN THE USA